

Multihead Weigher

# CCW-AS

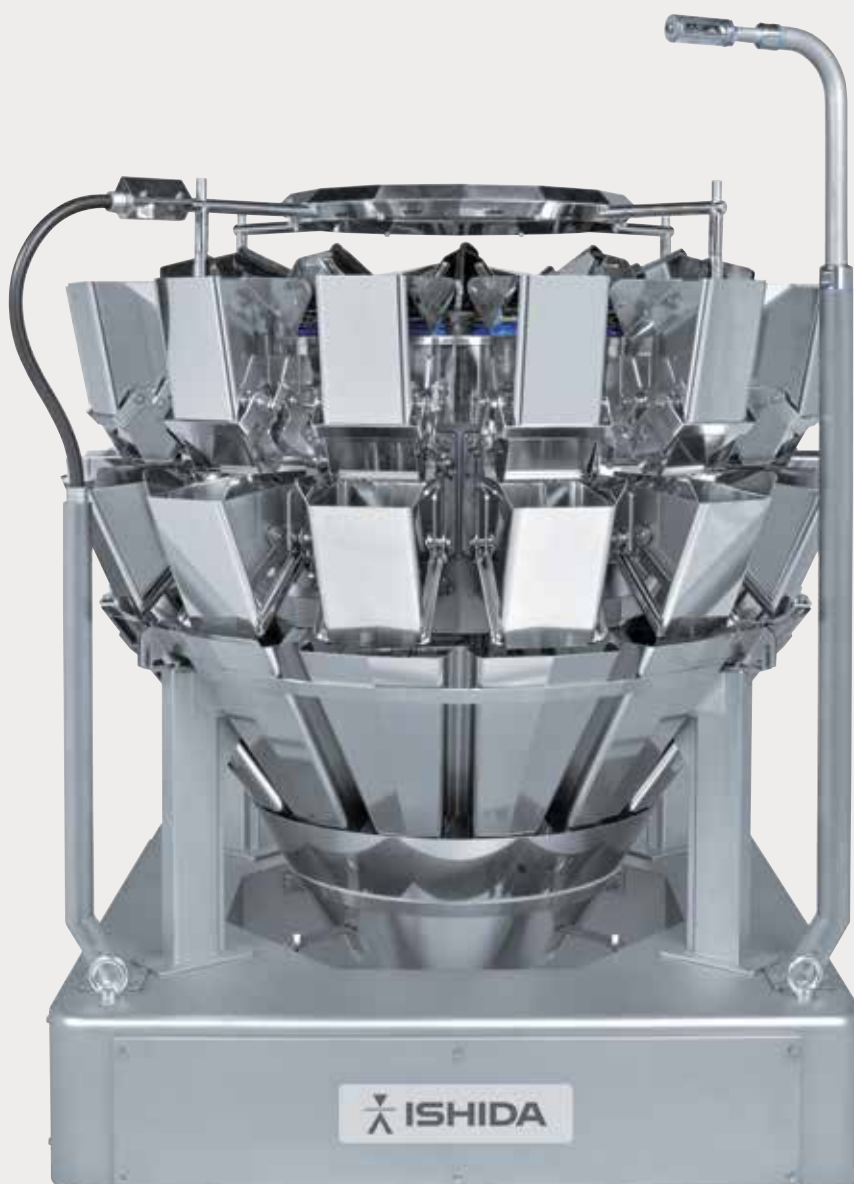

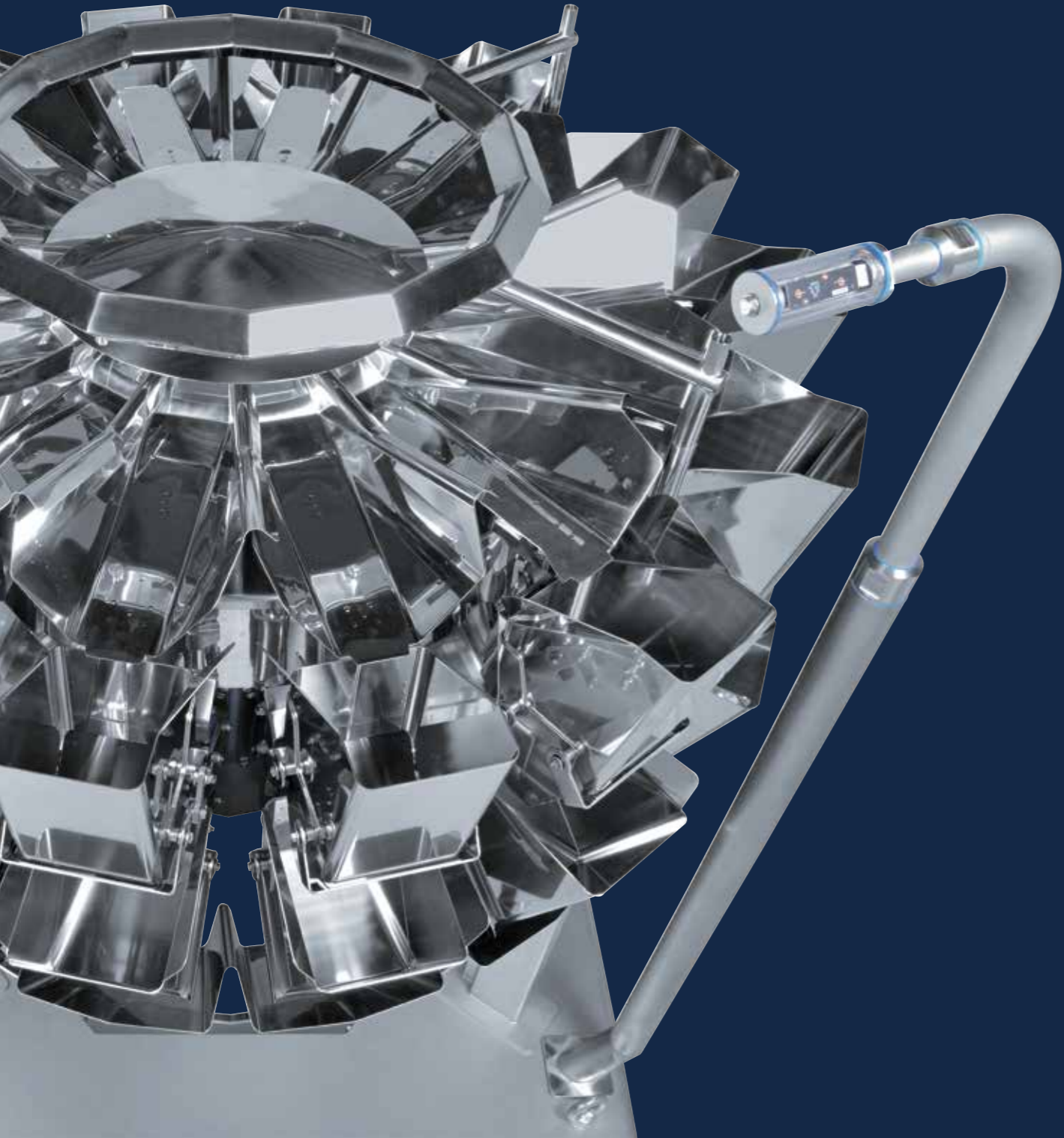

Multihead weighers



# Advantage Series

Based on more than 50 years of combination weighing know-how, additional functions improve productivity.

The CCW-AS multihead weigher increases OEE (Overall Equipment Effectiveness) and reduces workload through line automation.

Ishida continues to evolve as the market leader in multihead weighing, contributing to sustainable objectives and a diverse range of weighing solutions using the latest weighing technology. CCW-AS opens a new era for multihead weighing.



### Advanced productivity

The electrical platform has been fully re-designed to achieve higher accuracy and efficiency. New features are included such as Optical Charge Control (OCC), automatic adjustment of hopper open/close interval and new radial feeders help to enhance product feeding and maximise production output.



### Advanced operation

A redesigned drive unit improves hygiene and allows faster cleaning. Multiple cameras are mounted on the weigher to verify the machine status, thus minimising workload for the operator.



### Advanced interface & connectivity

A 15.6" colour LCD touch panel improves visibility and operation. The HMI is unified with other Ishida equipment for easy integration.



### Advanced ecological model

New motor drive control reduces power consumption and contributes to reduced environmental impact. The feeder drive control has been redesigned to minimise noise. Hygienic design features reduce cleaning time, waste and chemicals used.



## AS Features and benefits - Productivity

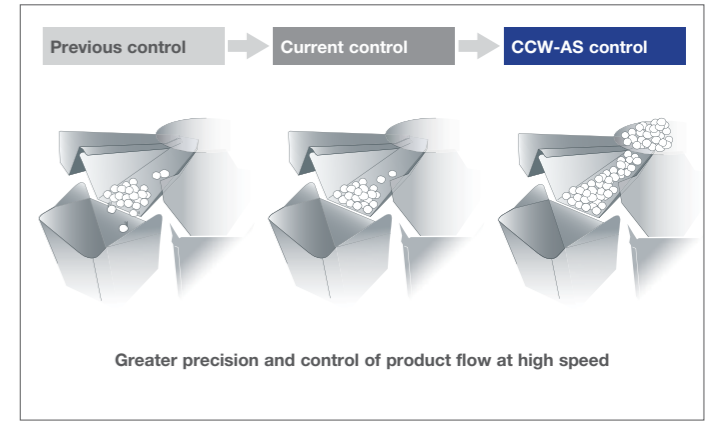

### Optimum feeding

Radial feeders are essential in combination weighing to feed product to the pool and weigh hoppers. The newly developed radial feeders have more conveying power for larger volumes and sticky products when compared with conventional feeders. By increasing the responsiveness of the feeders, the optimum quantity of product can be delivered to each weigh hopper, resulting in higher efficiency rates with more hoppers available for the combination, thus increasing speed and accuracy.

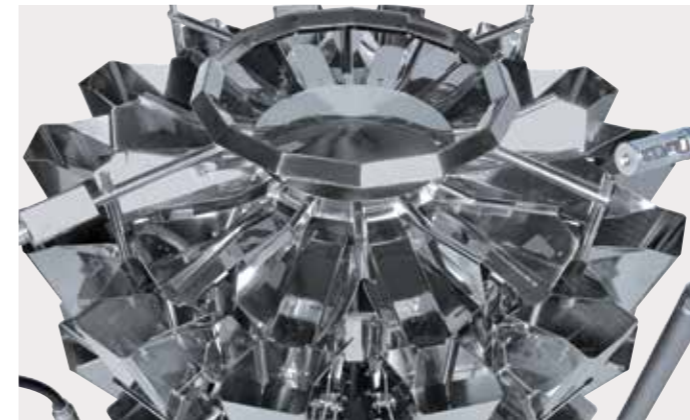

### Optical Charge Control (OCC)

High efficiency is achieved in applications such as snacks, where there may be erratic feeding conditions from upstream equipment. Sensors monitor the product layer on the trough, and the feeder drives vibrate to transfer the appropriate amount of product to each hopper (Optional).

### Improved radial feeder control

Unique feeder control with rapid response time enables product flow control at very high speeds, achieving small but precise weighments. In addition to the current control, CCW-AS enables precise control on even the largest volumes and sticky products which leads to greater weighing accuracy and less giveaway.

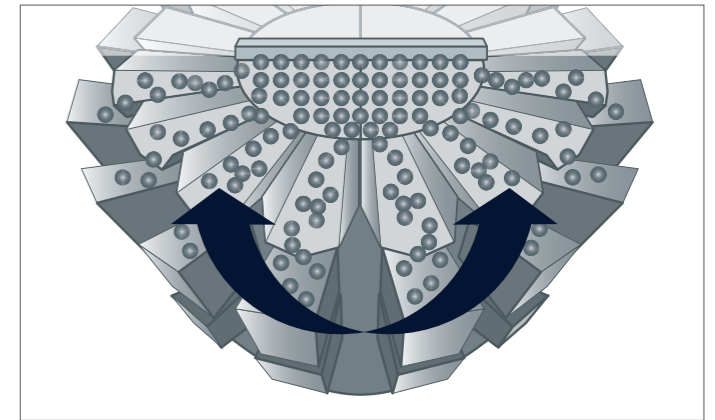

### Multi-Directional Dispersion Feeder (MDDF)

Product feeding condition onto the dispersion table is detected to allow alternating direction vibration and a stable flow of product to each trough to assist accuracy and improved weighments (Optional).

## AS features and benefits - Operation



### Advanced interface – HMI

Smartphone-like interface with intuitive graphical icons enable easy operation. Large 15.6" touch screen with swipe navigation and up to 500 pre-sets reducing human error and contributing to better labour usage, faster set-up and reduced costs.



### Vision system

Multiple cameras overhead and in the discharge chute monitor product conditions simultaneously to enhance and drive increased production efficiency. Live camera footage can be viewed from the operator's screen or remotely via an external network.

## AS features and benefits

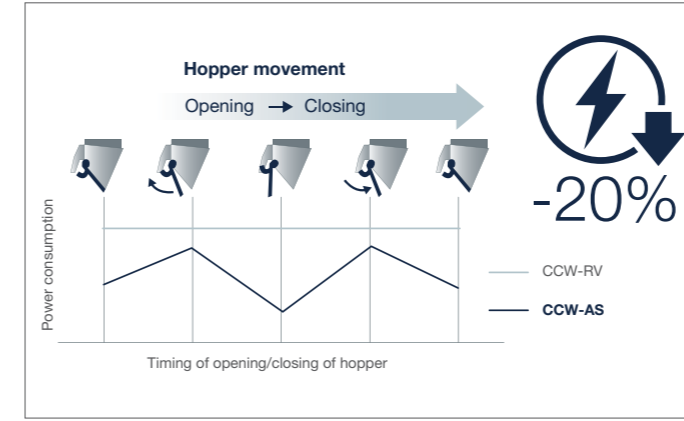

### Energy saving

Save energy and reduce running costs. The CCW-AS uses 20% less power than the previous model due to high efficiency hopper drive units and new unique software that controls power distribution during hopper operating cycles.

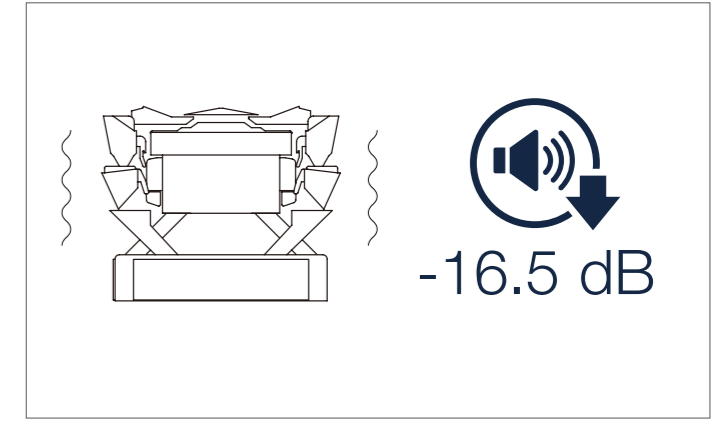

### Noise reduction

New feeder drive units and design improves the working environment for operators with reduced noise. Less impact and vibration improves the longevity of parts and lifetime costs.



### Auto hopper control

CCW-AS utilises mass data and automatically adjusts the movement and timing between hoppers. Even unskilled operators can adjust hopper open/close interval timings with high precision and operating rates, resulting in faster and more accurate weighments.

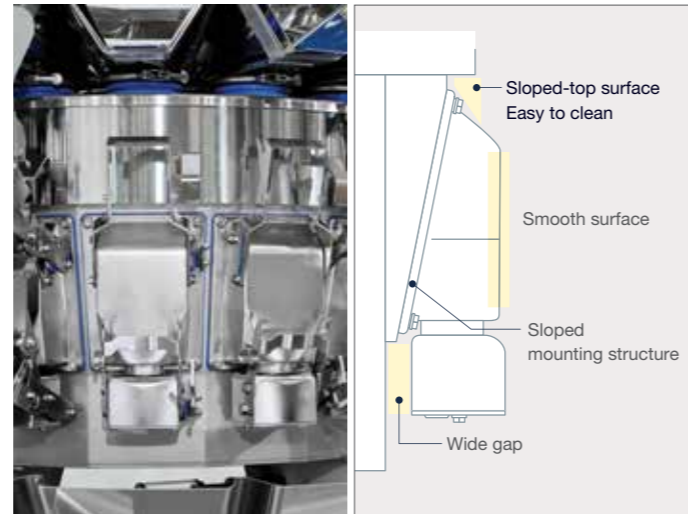

### Hygienic drive unit design

Even after long hours of production, build up of product debris on the drive units is significantly reduced. Smooth, sloping surfaces make cleaning easier and reduce downtime and consumables. This combines to increase uptime and output.

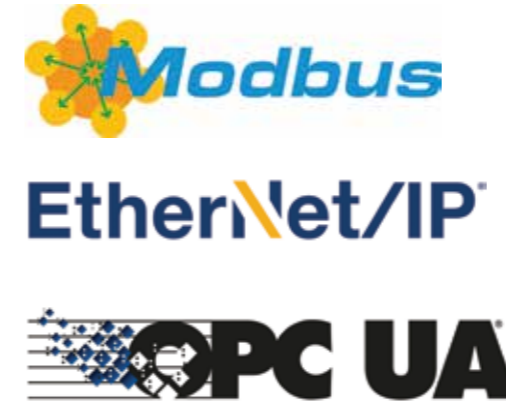

### Connectivity options

Full suite of data communication tools to provide advanced connectivity enhancing line control capabilities and efficiency, ensuring factory of the future ready with additional data collation, transfer and manipulation.



### Food Safety

With an IP69K rating, the CCW-AS waterproof model is suitable for even the harshest of environments. Extra food safety features include improved seals, ingress protection and robust design of contact parts to allow more aggressive cleaning.





# Working with you every step of the way

Our extensive R&D investment is directed at meeting the challenges of the fast-changing food industry around the globe.

We aim to support our partners fully, from the very start of the buying process, and you will find many equipment brochures, visual animations and case studies available on our website. When you are ready to make contact, a well-resourced network of Ishida companies, distributors and agents, extending across Europe, the Middle East and Africa, can provide advice and organise demonstrations and trials.

Installation is rapid and efficient. For integrated packing lines, we use proven project management techniques and methodologies, tuned to your key objectives and specifications.

A dedicated pan-European service engineering team helps to maximise the performance, functionality and reliability of our installed base. In addition, spares facilities are strategically placed throughout the territory, offering 24-hour delivery in most cases.



helpline • spares • service • training

**ISHIDA EUROPE LIMITED**  
Kettles Wood Drive  
Woodgate Business Park  
Birmingham  
B32 3DB  
United Kingdom  
Tel: +44 (0)121 607 7700  
Fax: +44 (0)121 607 7888  
info@ishidaeurope.com

**ISHIDA CZECH REPUBLIC**  
Tel: +420 220 960 422  
info@ishidaeurope.cz

**ISHIDA NETHERLANDS**  
Tel: +31 (0)499 39 3675  
Fax: +31 (0)499 39 1887  
info@ishida.nl

**ISHIDA EAST AFRICA**  
Tel: +254 (0)20 8124333  
info@ishidaeurope.com

**ISHIDA ROMANIA**  
Tel: +40 731 34 79 34  
info@ishidaeurope.com

**ISHIDA FRANCE**  
Tel: +33 (0)1 48 63 83 83  
Fax: +33 (0)1 48 63 24 29  
info@ishidaeurope.fr

**ISHIDA SOUTH AFRICA**  
Tel: +27 (0)11 976 2010  
Fax: +27 (0)11 976 2012  
info@ishidaeurope.com

**ISHIDA GERMANY**  
Tel: +49 (0)791 945 160  
Fax: +49 (0)791 945 1699  
info@ishida.de

**ISHIDA SWEDEN**  
Tel: +46 (0)31 871 320  
info@ishidaeurope.se

**ISHIDA MIDDLE EAST**  
Tel: +971 (0)4 299 1933  
Fax: +971 (0)4 299 1955  
ishida@ishida.ae

**ISHIDA SWITZERLAND**  
Tel: +41 (0)41 799 7999  
Fax: +41 (0)41 790 3927  
info@ishida.ch