

QX-Flex Range

A powerful family of advanced
tray sealing solutions





Tray sealer

QX-Flex Range

Outstanding tray sealing technologies for the many different demands of today's food industry.

Whether you pack a single product or many different products per shift; whether you operate short, medium or long production runs, Ishida offers you a state-of-the-art response to the challenges you face.

Developed in consultation with world-leading retailers, our tray sealing solutions deliver the highest standards of pack appearance, convenience, shelf-life, safety and hygiene. Capable of working with your chosen tray and film we can deliver exactly the seal type, pack appearance, atmosphere and functionality you require.

Designed precisely for the situations you face everyday, the QX-Flex range offers all the benefits of advanced automation while making the smartest use of your floorspace, materials and budget.

Ishida's experience of tray loading, sealing and subsequent handling extends to all the world's markets and includes applications such as meat, poultry, ready meals, salads, fish & seafood and dairy products.

The benefits of single-source supply

In choosing an Ishida tray sealer you can be confident that our long experience of designing, manufacturing and installing all the surrounding and related equipment is at your disposal. Our products and services include multihead weighers, seal testers, checkweighers, X-Ray and vision inspection systems, snack food bagmakers, weigh-batchers and pick-and-place casepacking systems, consultancy and project management.



Meat



Poultry



Ready Meals



Salads



Fish & seafood



Dairy

QX-300 Flex

Superb sealing results for semi-automatic production

When new food products need professional presentation from the start, the QX-300 semi-automatic tray sealer gives you a wide range of tray and seal options, offering serious production speeds of up to eight cycles per minute, with up to six trays per cycle.

It's also the perfect solution when you want to develop and test products without taking up time on your fully-automatic production and packing lines.

- ▲ Entry level machine suitable for moderate production throughput with a robust and hygienic design
- ▲ A space-saving, highly mobile unit that can be rapidly switched from one production area to another
- ▲ The same wide choice of tray-type, seal-type and atmosphere as our fully-automatic models
- ▲ Simple set-up and operation, easy tool-swapping for rapid changeovers

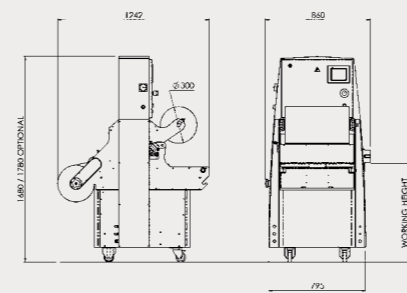

Specification

Specification	QX-300
Maximum tray width	415mm
Tool formats	Seal Only and MAP Skinpack
Type of film cut	Outside cut with 2-5mm overhang for laminate and shrink films
Maximum tray height	130mm
Number of impressions per tool	From 1 to 6
Maximum cycle speed	8 cycles per minute
Maximum film reel diameter	300mm
Machine weight	450kg
Supply voltage (integrated transformer for 200V)	16A 200VAC + E 3 phase 50-60HZ
Air consumption	109nL/MIN @ 0.6 MPa (Maximum)

QX-775 Flex

Versatile single-lane packing for moderate-to-high throughput

Often seen as the well-established standard in modern sealing, particularly for fresh foods, the QX-775 can handle all types of trays, delivering top quality seals at impressive speeds. Owing to their versatility and the ease and speed of changeovers, many QX-775 tray sealers are serving companies that have a wide range of fresh products, each with different pack and atmosphere requirements.

- ▲ Up to 15 cycles per minute, sealing up to six trays per cycle (with MAP)
- ▲ Excellent results with board, plastic and aluminium trays
- ▲ Handles all pack types, including skinpack and slice-pack, up to 300mm width
- ▲ For MAP (modified atmosphere packaging), features integrated gas mixing, analysing and coding
- ▲ Easy set-up and operation, including rapid, motor-assisted tool changeover
- ▲ Robust, hygienic design enables rapid, effective cleaning



QX-775 features and benefits

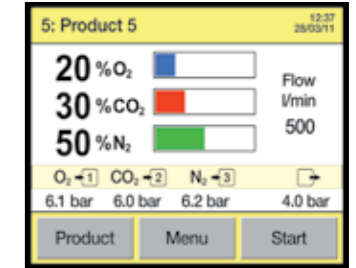
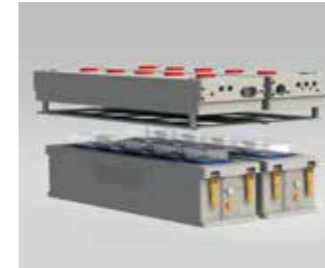

Head redundancy option

This feature allows an impression to be isolated during production in the event of a damaged knife or heater for example. The machine can then continue to run to the end of the shift where repairs can then be made.

Hygienic design

Open design allows easy access for rapid cleaning and fast changeovers.

Easy operation and set up

Simple to set up and operate, with up to 100 presets for total line configuration.

Integrated gas mixing, analysing and coding

Integrated gas mixing, analysis, with 'wrong mix' automatic cut-out.

Technical specification

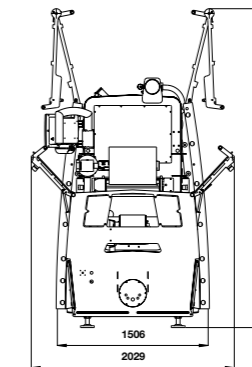
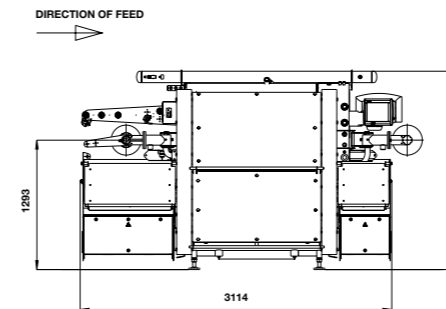

Specification

Maximum tray width
Tool formats
Type of film cut
Maximum tray height
Number of impressions per tool
Maximum cycle speed
Maximum film reel diameter
Machine weight (without tool)
Supply voltage
Air consumption

QX-775

300mm
Seal Only and MAP Skinpack
Inside or outside cut
130mm
From 1 to 6
15 cycles per minute
300mm
2000kg
32A 380-415VAC + N + E 3 phase 50-60 HZ
120nL/MIN @ 0.55 MPa (Maximum)

QX-1100 Flex

Three high-throughput solutions
to exactly match your production
approach

The Ishida QX-1100 Tray Sealer has been recognised as a major step forward in smart tray sealer design, with its use of advanced servo-technology, its intuitive interface and its open, accessible design.

Today, the QX-1100 is available in three different configurations, ensuring a close fit to the types of products you pack, the volume you want to achieve and the frequency of product or tray-type changeovers.

For all three configurations:

- ▲ Sealing is a high-speed, high-precision operation delivering top-flight appearance and functionality across all pack types, including skinpack and slice-pack
- ▲ Selected sealing heads can be excluded (e.g. in the event of a knife or heater issue). Trays are automatically re-routed and production can continue under circumstances that would cause delays with conventional tray sealers
- ▲ Operators of all skill levels find the QX-1100 easy to set up and operate
- ▲ Thorough cleaning is quick and simple, with quick-release or simple lift-off of parts and rapid self-draining of washdown solutions
- ▲ Tool-swapping is largely automated, reducing manual handling during changeover



Ishida QX-1100 Single Lane

High production throughput, especially suitable for larger tray sizes

This single-lane version of the QX-1100 Flex can seal large trays (up to 400mm in width), up to seven at a time. At 15 cycles per minute, this means an impressive throughput of up to 105 trays per minute, making it particularly suitable for large production runs.



Ishida QX-1100 Twin Lane

Fastest tray sealing speeds available, delivering maximum capacity

Designed for medium-sized and small trays, this twin-lane version, with its maximum of 14 sealing heads, can achieve speeds of up to 210 trays per minute, one of the fastest in the industry. The QX-1100 Twin Lane thus allows you to achieve phenomenal returns on floor space.

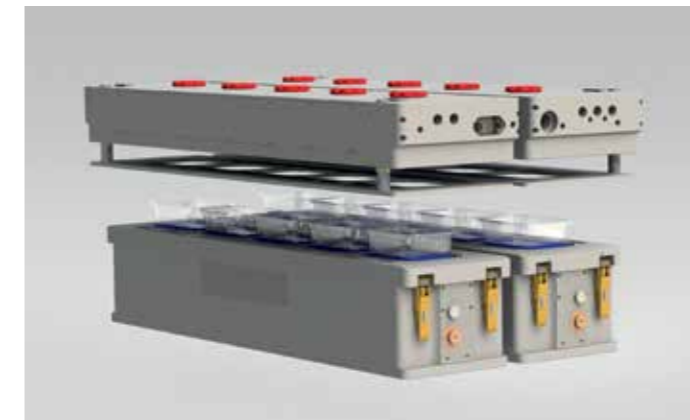

Ishida QX-1100 SDL (Split Dual Lane)

Extraordinary versatility and speed for complex or varying product ranges

Where you have a high overall throughput but great variety in run-length and more than a few different products to pack, the SDL offers you a unique opportunity to really get the maximum out of your floorspace. Each lane of this unique machine can run completely independently of the other, with different speeds, separate products, trays, films, pack atmospheres and target weights. You thus have two tray sealers, each fast and highly versatile, running within the footprint of a single machine: an immediate space saving of 50%!

QX-1100 features and benefits

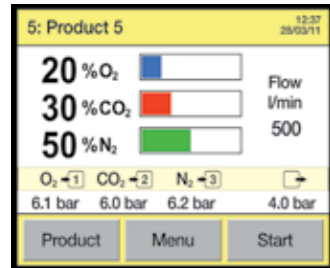

Integrated gas mixing, analysing and coding

Integrated systems produce exactly the specified gas mixture, then rigorously monitor it.



Rapid changeovers and washdown

Automatic and quick-release features plus self-draining design ensure rapid cleaning and changeovers.



Flexible by design

The QX-1100 can be optimised to suit all product types, trays and film materials.

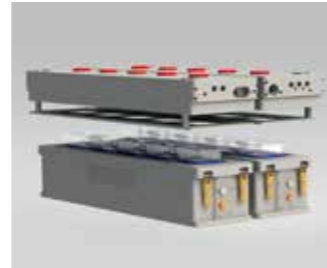

Head redundancy option

This feature allows an impression to be isolated during production in the event of a damaged knife or heater for example. The machine can then continue to run to the end of the shift where repairs can then be made.

Technical specification

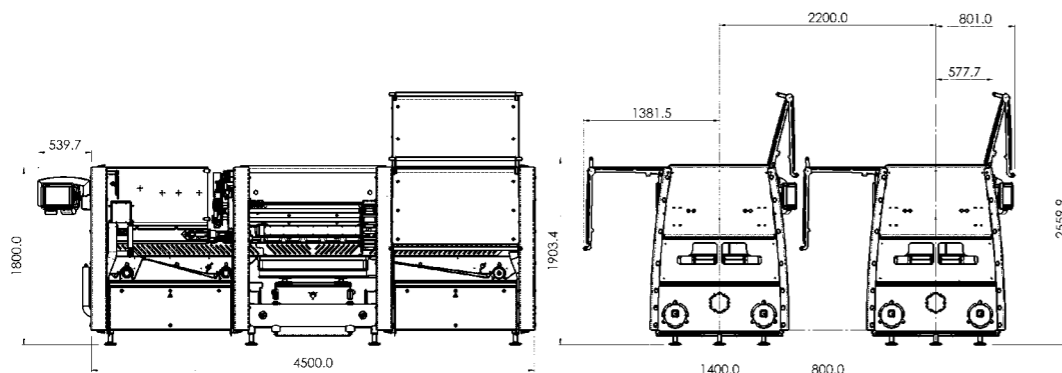

Specification	QX-1100-SL Single Lane	QX-1100-TL Twin Lane	QX-1100-SDL Split Dual Lane
Maximum tray width	400mm	220mm	195mm
Tool formats	Seal Only and MAP Skinpack		
Type of film cut	Inside or outside cut		
Maximum tray height	130mm		
Number of impressions per tool	From 1 to 7	From 2 to 14	From 1 to 7 per lane
Maximum cycle speed	15 cycles per minute		
Maximum film reel diameter	400mm	400mm	450mm
Machine weight (without tool)	2800kg		
Supply voltage	32A 380-415VAC + N + E 3 phase 50-60 HZ	32A 380-415VAC + N + E 3 phase 50-60 HZ	32A 380-415VAC + N + E 3 phase 50-60 HZ per lane
Air consumption	140nL/MIN @ 0.55 MPa (Maximum)	140nL/MIN @ 0.55 MPa (Maximum)	70nL/MIN @ 0.55 MPa (Maximum) per lane

Rely on Ishida to realise your vision

Ishida Solutions is a team of experienced, creative visioneers, engineers and planners dedicated solely to major packing line projects.

Special expertise is needed to advise on the best possible combination of equipment to achieve your goals, and on how to squeeze maximum synergy from the often complex interfaces between the elements of the line. We can provide that expertise at any stage in your planning, from earliest brainstorming through to reliable, detailed project management.

Here are some of the ways in which Ishida Solutions can help you maximise efficiency and minimise cost per pack:

1. New ideas that work

We offer bright inventive minds with a track record of innovation across a wide range of applications, opportunities and challenges you face.

2. A unique food industry resource

We have many years of successful experience with a wide range of food companies, including most of the world's top 10. No other solutions or project management service can offer you this level of food industry expertise.

3. The highest level of packing line integration

We offer our own full range of single-manufacturer packing line machines and equipment, with 'integrability' designed-in from the start. This is complemented by state-of-the-art expertise in integrating machines from a wide range of other sources.

4. Planning and management that minimise risk and cost

Ishida implementation systems have been tried and tested in thousands of successful installations. We also have a sound grasp of methodologies specific to the world's top food manufacturers, as well as the adaptability to work effectively with whichever approach you choose.

5. The resources to assure ongoing peak performance

Our work will result in an installation capable of performance to or above the agreed specification, far into the future. Whatever the geography of your operation, we can provide you with any necessary support, including service and spares, backed by our wide knowledge of production challenges and solutions across many markets.



Working with you every step of the way

Our extensive R&D investment is directed at meeting the challenges of the fast-changing food industry around the globe.

We aim to support our partners fully, from the very start of the buying process, and you will find many equipment brochures, visual animations and case studies available on our website. When you are ready to make contact, a well-resourced network of Ishida companies, distributors and agents, extending across Europe, the Middle East and Africa, can provide advice and organise demonstrations and trials.

Installation is rapid and efficient. For integrated packing lines, we use proven project management techniques and methodologies, tuned to your key objectives and specifications.

A dedicated pan-European service engineering team helps to maximise the performance, functionality and reliability of our installed base. In addition, spares facilities are strategically placed throughout the territory, offering 24-hour delivery in most cases.



helpline • spares • service • training

ISHIDA EUROPE LIMITED
Kettles Wood Drive
Woodgate Business Park
Birmingham
B32 3DB
United Kingdom
Tel: +44 (0)121 607 7700
Fax: +44 (0)121 607 7888
info@ishidaeurope.com

ISHIDA CZECH REPUBLIC
Tel: +420 220 960 422
info@ishidaeurope.cz

ISHIDA ROMANIA
Tel: +44 (0)121 607 7700
Fax: +44 (0)121 607 7888
info@ishidaeurope.ro

ISHIDA FRANCE
Tel: +33 (0)1 48 63 83 83
Fax: +33 (0)1 48 63 24 29
info@ishidaeurope.fr

ISHIDA RUSSIA AND CIS
Tel: +7 499 272 05 36
Fax: +7 499 272 05 37
info@ishidaeurope.ru

ISHIDA GERMANY
Tel: +49 (0)791 945 160
Fax: +49 (0)791 945 1699
info@ishida.de

ISHIDA SOUTH AFRICA
Tel: +27 (0)11 976 2010
Fax: +27 (0)11 976 2012
info@ishidaeurope.com

ISHIDA MIDDLE EAST
Tel: +971 (0)4 299 1933
Fax: +971 (0)4 299 1955
ishida@ishida.ae

ISHIDA SWEDEN
Tel: +46 (0)31 871 320
info@ishidaeurope.se

ISHIDA NETHERLANDS
Tel: +31 (0)499 39 3675
Fax: +31 (0)499 39 1887
info@ishida.nl

ISHIDA SWITZERLAND
Tel: +41 (0)41 799 7999
Fax: +41 (0)41 790 3927
info@ishida.ch