

IX-G2 Poultry Solutions

X-ray inspection system

The fast, reliable route to
bone-free poultry fillets





Poultry



Ishida Poultry Solutions: reliable, high-speed bone fragment detection in a plug-and-play, cost-effective package

The Ishida IX-G2 Poultry solutions offer the highest levels of bone detection coupled with low false positive rates all wrapped up in a cost effective, small footprint solution that can easily integrate in to your line.

Challenge

The successful detection of chicken bone has long proven to be one of the X-ray industries toughest challenges. With the age of the birds at time of processing typically being from 4 to 6 weeks the calcium level in the bones required for detection by traditional X-ray solutions does not have time to fully develop.

Dual Energy

The IX-G2 system utilises a dual energy principle that allows low contrast objects such as chicken bone to be reliably detected. The system is equipped with a special two layer detector that allows both the high energy and low energy signals to be measured.

Standard X-ray systems that are typically employed for end of line packaged products use only a single layer detector looking at the higher energy spectrum which is adequate for the detection of metals and high density materials.

The ability to measure at both the high and lower energy levels allows a composite image to be constructed that effectively removes the product effect and highlights the areas containing even the smallest bone fragments.

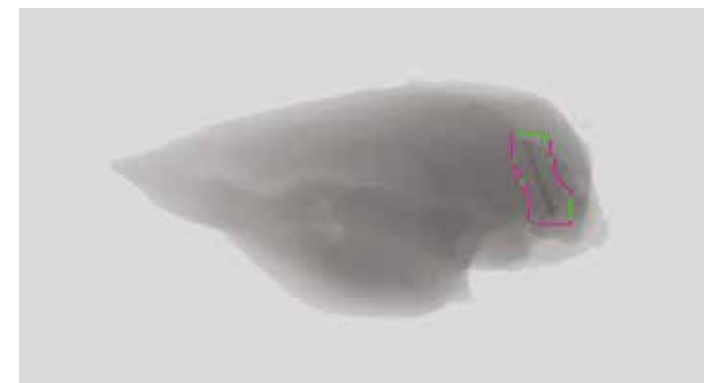

Chicken fillet inspection with the wish bone



High speed dual lane reject system



17" Touch screen

Beyond Bone

The ability to detect other foreign material should not be overlooked. The IX-G2 is equipped with a range of detection algorithms that are able to detect both bone as well other foreign materials with stainless steel detection levels below 0.6mm in most cases. Other foreign bodies such as stones, glass and rubbers can all be easily detected.

Applications

Most commonly the IX-G2 is installed to ensure that breast fillets are bone free. However, the machine is equally at home inspecting inner fillets, de-boned thighs and butterfly fillets.

- ▲ inner fillets
- ▲ de-boned thighs and
- ▲ butterfly fillets

Solutions

The IX-G2 solution is available in both single and dual lane variants depending on the individual application requirements giving throughputs in excess of 220 fillets per minute.



Easy Integration

With the smallest footprint compared to other solutions and only requiring a 3-phase supply and compressed air connection the machine can be in place and commissioned with the minimal amount of production disruption and no need to adjust layouts to free up valuable line space.

Ease of Use

The systems auto learn feature allows new products to be set up in minutes with a minimum amount of prior training. Once set the system can be simply adjusted, each reject image is stored and the defective area highlighted in a specific colour on the image. The associated level can then be simply adjusted using the graphical representation on screen to optimise probability of detection with the lowest level of false positives.

Cleaning

Quick tool less disassembly allows for key components to be quickly and easily removed for separate cleaning. The optional trolley keeps all removed parts together for simple reassembly with all parts to hand when required. The front and rear access doors both up and down stream allow full access in to the remainder of the machine for effective wash down at the end of every production run.

Specifications		IX-G2-4027
Inspection range	Length	20 to 450mm (snap mode) Interval between inspection objects: 30mm
	Width	400mm
	Height	Max. 80mm*
Inspection conveyor dimension	Length	800mm (Option to increase)
	Width	430mm
	Height	Height to belt 900mm (+/-50mm)
Transfer speed		10 to 60 m/min
Transfer weight		Max. 5kg (Standard)
X-ray output		Max. 350W / 100 kV / 5mA
Operating section		17" TFT LCD Touch screen Windows OS
Number of presets		100 items (expandable)
Machine material & finish		Stainless Steel (SUS304) in bead blast finish
Machine protective construction		IP66 (product area) IP65 (non product area)
Cooling method		Hermetical Air Cooling
X-ray leakage radiation dose		1uSv/h or less (including conveyor transfer entrance/exit)
Power supply		Three phase AC415V, 16A
Operation environment		Temperature: 0 to 35 degree (no rapid temperature change) Humidity: 30 to 85%RH (without condensation)

*Aperture height is 150mm. Maximum passable product height is 80mm.

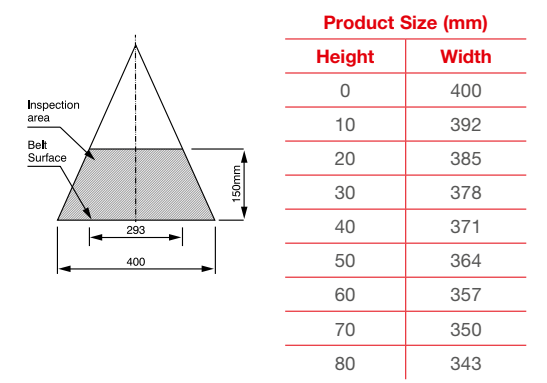

Inspection area
The figures show the permissible inspection range. Portions of the product which are not within the shaded area are not irradiated.

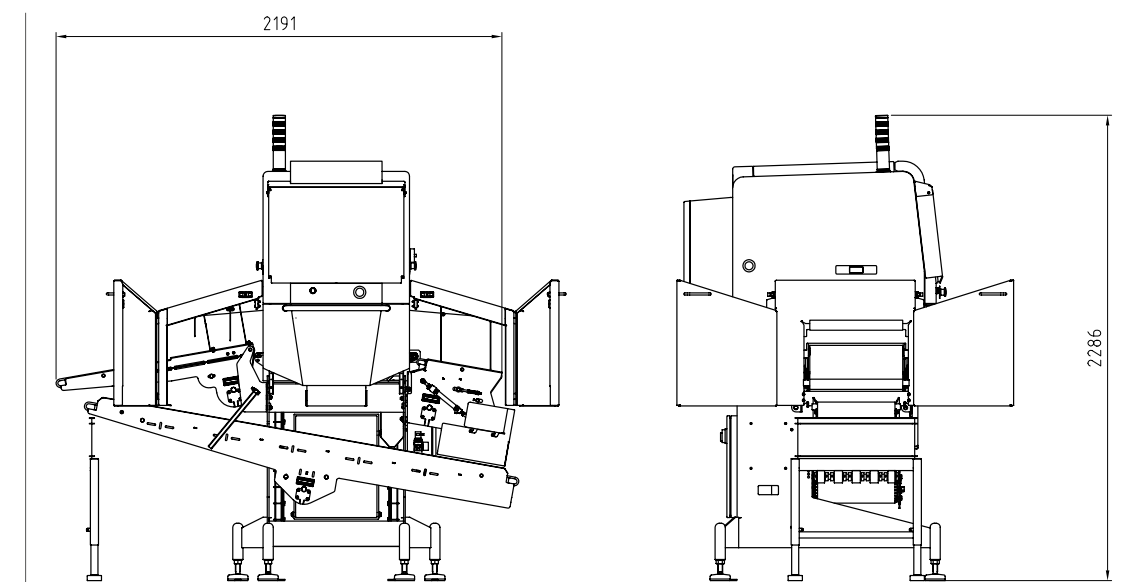

All information supplied within is correct at time of publication. Ishida Europe pursues a policy of continual improvement due to technical development. We therefore reserve the right to deviate from information, descriptions, and specifications in this publication without notice. Ishida Europe shall not be liable for errors contained herein or for incidental or consequential damages in connection with the furnishing, performance or use of this material.

Working with you every step of the way

Our extensive R&D investment is directed at meeting the challenges of the fast-changing food industry around the globe.

We aim to support our partners fully, from the very start of the buying process, and you will find many equipment brochures, visual animations and case studies available on our website. When you are ready to make contact, a well-resourced network of Ishida companies, distributors and agents, extending across Europe, the Middle East and Africa, can provide advice and organise demonstrations and trials.

Installation is rapid and efficient. For integrated packing lines, we use proven project management techniques and methodologies, tuned to your key objectives and specifications.

A dedicated pan-European service engineering team helps to maximise the performance, functionality and reliability of our installed base. In addition, spares facilities are strategically placed throughout the territory, offering 24-hour delivery in most cases.



helpline • spares • service • training

ISHIDA EUROPE LIMITED
Kettles Wood Drive
Woodgate Business Park
Birmingham
B32 3DB
United Kingdom
Tel: +44 (0)121 607 7700
Fax: +44 (0)121 607 7888
info@ishidaeurope.com

ISHIDA CZECH REPUBLIC
Tel: +420 220 960 422
info@ishidaeurope.cz

ISHIDA ROMANIA
Tel: +4 021 326 69 81
Fax: +4 021 326 69 82
info@ishidaeurope.ro

ISHIDA EAST AFRICA
Tel: +254 (0)202 000425
info@ishidaeurope.com

ISHIDA RUSSIA AND CIS
Tel: +7 499 272 05 36
Fax: +7 499 272 05 37
info@ishidaeurope.ru

ISHIDA FRANCE
Tel: +33 (0)1 48 63 83 83
Fax: +33 (0)1 48 63 24 29
info@ishidaeurope.fr

ISHIDA SOUTH AFRICA
Tel: +27 (0)11 976 2010
Fax: +27 (0)11 976 2012
info@ishidaeurope.com

ISHIDA GERMANY
Tel: +49 (0)791 945 160
Fax: +49 (0)791 945 1699
info@ishida.de

ISHIDA SWEDEN
Tel: +46 (0)31 871 320
info@ishidaeurope.se

ISHIDA MIDDLE EAST
Tel: +971 (0)4 299 1933
Fax: +971 (0)4 299 1955
ishida@ishida.ae

ISHIDA SWITZERLAND
Tel: +41 (0)41 799 7999
Fax: +41 (0)41 790 3927
info@ishida.ch

ISHIDA NETHERLANDS
Tel: +31 (0)499 39 3675
Fax: +31 (0)499 39 1887
info@ishida.nl