

Ishida Europe: understanding and tackling the weighing and packing line challenges you face

- We pride ourselves on working closely with customers worldwide across a broad range of sectors including snack foods, meat, fresh produce, ready meals, poultry, confectionery, biscuits and bakery, fish and seafood, cereals, pasta, dairy, granules and powders, pet foods and non-food
- Our unique engineering expertise and in-depth knowledge are based on continuous activity across an extensive variety of applications and our long-standing brand heritage
- Hands-on involvement with our customers enables us to maximise our engineering skills to meet the individual challenges they face daily

- We commit our R&D resources to delivering the innovative solutions and ongoing support our customers can count on

- Our customer-first policy creates intelligent solutions that include:

- Traditional multihead weighers
- Fresh Food Weighers
- Bagmakers for Snacks
- Traysealers
- X-ray inspection systems
- Seal testers for trays and pillow packs
- Checkweighers
- Weigh Price Labellers
- Pick-and-place systems
- Complete packing lines



Working with you every step of the way

Our extensive R&D investment is directed at meeting the challenges of the fast-changing food industry around the globe.

We aim to support our partners fully, from the very start of the buying process, and you will find many equipment brochures, visual animations and case studies available on our website. When you are ready to make contact, a well-resourced network of Ishida companies, distributors and agents, extending worldwide can provide advice and organise demonstrations and trials.

Installation is rapid and efficient. For integrated packing lines, we use proven project management techniques and methodologies, tuned to your key objectives and specifications.

A dedicated service engineering team helps to maximise the performance, functionality and reliability of our installed base. In addition, spares facilities are strategically placed throughout the territory, offering 24-hour delivery in most cases.

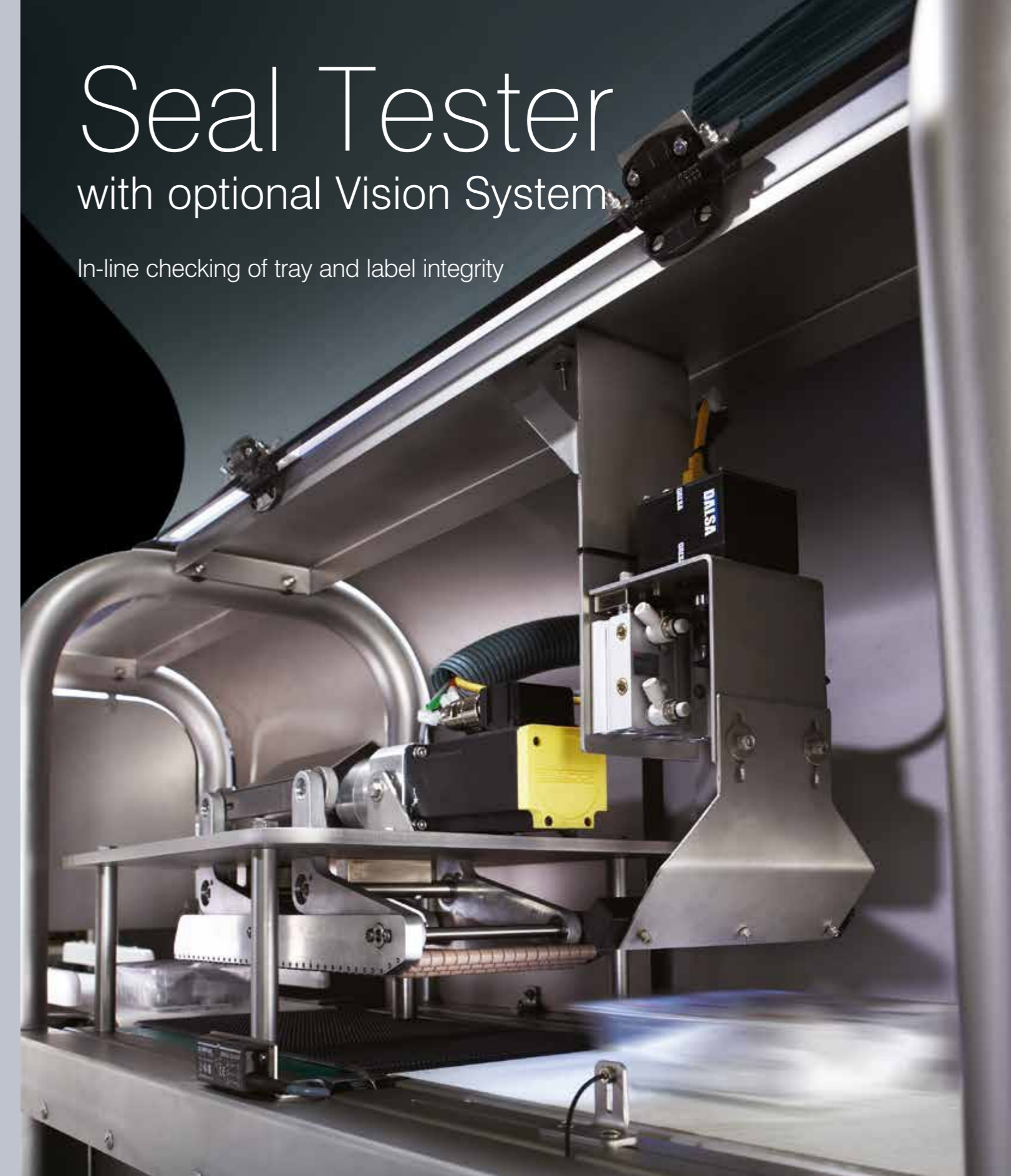
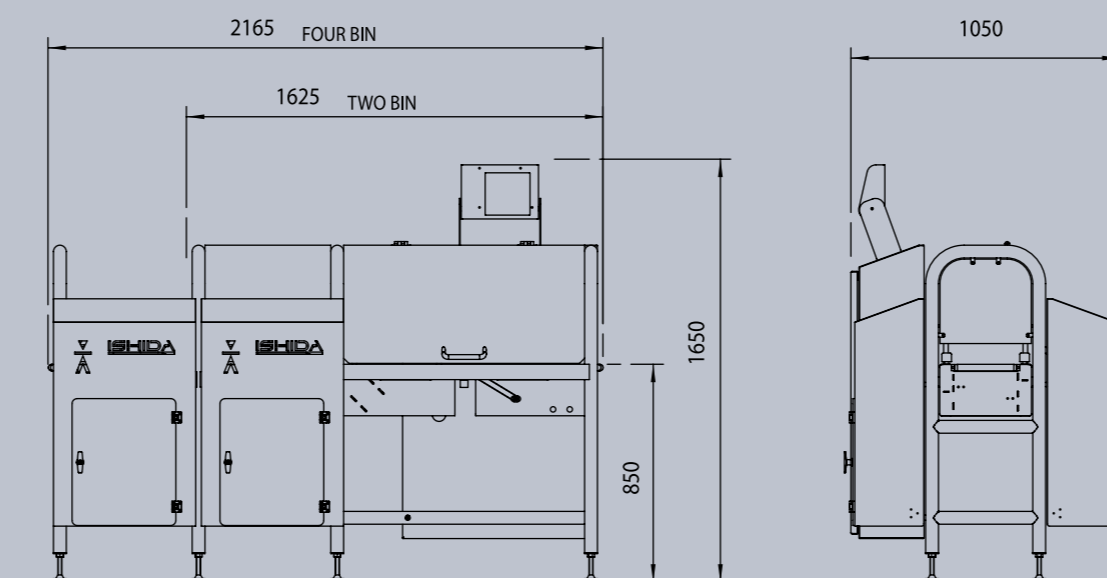

Seal Tester

with optional Vision System

In-line checking of tray and label integrity



ISHIDA EUROPE LIMITED
Kettles Wood Drive
Woodgate Business Park
Birmingham
B32 3DB
United Kingdom
Tel: +44 (0)121 607 7700
Fax: +44 (0)121 607 7666
info@ishidaeurope.com

ISHIDA CZECH REPUBLIC
Tel: +420 317 844 059
Fax: +420 317 844 052
info@ishidaeurope.cz

ISHIDA ROMANIA
Tel: +40 (0)21 589 73 52
Fax: +40 (0)21 310 34 22
info@ishidaeurope.ro

ISHIDA FRANCE
Tel: +33 (0)1 48 63 83 83
Fax: +33 (0)1 48 63 24 29
info@ishidaeurope.fr

ISHIDA RUSSIA AND CIS
Tel: +7 499 272 05 36
Fax: +7 499 272 05 37
info@ishidaeurope.ru

ISHIDA GERMANY
Tel: +49 (0)791 945 160
Fax: +49 (0)791 945 1699
info@ishida.de

ISHIDA SOUTH AFRICA
Tel: +27 (0)11 976 2010
Fax: +27 (0)11 976 2012
info@ishidaeurope.com

ISHIDA MIDDLE EAST
Tel: +971 (0)4 299 1933
Fax: +971 (0)4 299 1955
ishida@ishida.ae

ISHIDA SWITZERLAND
Tel: +41 (0)41 799 7999
Fax: +41 (0)41 790 3927
info@ishida.ch

ISHIDA NETHERLANDS
Tel: +31 (0)499 39 3675
Fax: +31 (0)499 39 1887
info@ishida.nl



New confidence in total tray integrity

Ishida Seal Tester: fast, accurate, in-line detection of tray seal defects

The Ishida Seal Tester is designed specifically to test the integrity of sealed, flow-wrapped or lidded trays. As well as detecting significant leakage, it can pick up any trends that might give early warning of deterioration in the sealing process.

It works by applying controlled pressure to the pack and detecting and evaluating any subsequent 'give'. The Seal tester enables food packers to be completely confident in the packs they supply, yet it is gentle and non-destructive in operation.

Highly accurate, even at high speeds, the Seal Tester is also extremely versatile. It can test packs on a continuous or intermittent basis, and can also be used to establish the maximum 'safe' pressure that can be applied to a given pack.

A choice of two or four reject bins is available. The Seal Tester also makes a perfect platform for an Ishida Vision System, capable of checking most important aspects of pack labelling. Adding the Vision System very cost-effectively converts the Seal Tester into a comprehensive pre-casepacking checking centre for trays.

- Speeds of up to 140ppm
- Highly accurate leak detection, even on large trays
- Simple set-up, operation and changeover
- Works with most tray types and materials, in continuous or intermittent mode
- Options include Ishida Vision System for comprehensive label checking



The speed you need to keep production flowing

Able to handle packs at up to 140ppm, the Ishida Seal Tester also prevents production hold-ups by rejecting any 'time wasters' (such as packs stuck together or of the wrong size) without leak-testing them.



Unerring detection of leaks at high speeds

Leak-testing accuracy depends on the ability of the test plate to make smooth contact with the moving tray and apply the correct pressure for long enough to produce satisfactory readings. To achieve this, Ishida uses its own vibration-free servomotor technology and extensive seal-testing experience. The table shows the results.

Speed	Size of pinhole that will reliably be detected
100bpm	0.5mm
130bpm	0.75mm



Simple to use

Operators benefit from an easy-to-read touchscreen, with seven languages available. All parameters for each pack type are stored as presets. No cranking of the pressure plate to suit each different tray height: everything adjusts at the touch of a button.



Versatile

The Ishida Seal Tester works on trays up to 80mm in height and 350mm x 220mm in area. Packs can be of plastic or aluminium and packed under air, MAP or CAP. Continuous operation is the norm, but the system can be set to test packs arriving on an intermittent basis, using a longer dwell time for even greater security. The test plate is capable of applying pressure from 500g to 80kg, and can therefore be used to test a pack to its limits.



Designed for food industry conditions

The Ishida Seal Tester, with its sensitive testing equipment and electronics, is protected by a streamlined, water resistant case that allows complete access for cleaning and maintenance.



Ishida Vision System: intelligent policing of all aspects of your labelling

An Ishida Vision System can check that your trays carry the correct labels, properly applied. It can also verify the overprinted information, including numbers, barcodes and 2D codes, while checking its legibility. The Vision System will link with appropriate data across your system to carry out verification, and can send images and results for archiving as evidence.

An extremely cost-effective option, the Ishida Vision System uses the reject system of the Ishida Seal Tester to remove any non-compliant packs from your output, protecting your reputation as well as that of the brands you pack. It contributes to the maintenance of proper traceability and greatly reduces the chances of returns and fines.

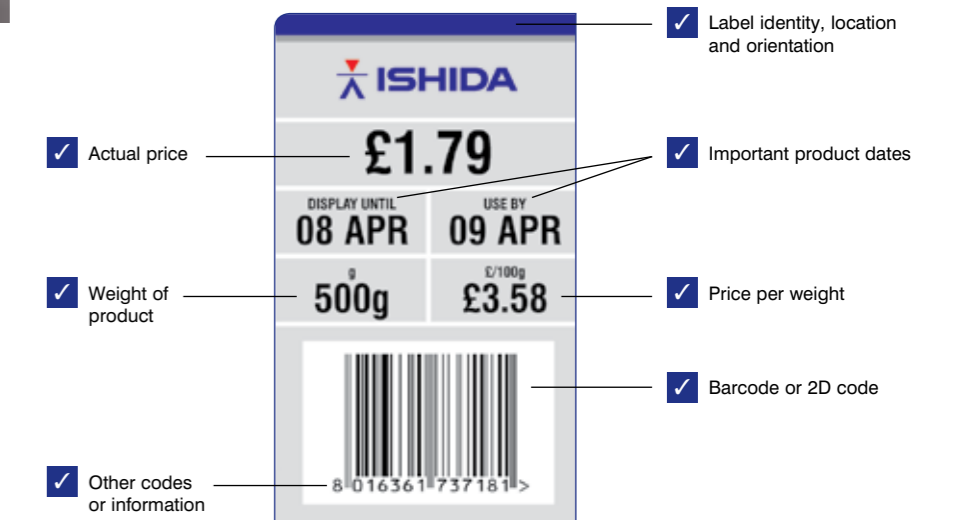

Some of the label parameters checked by the Ishida Vision System

