



ATLAS-B-RS23-SB20-SNR(L)-AAN ATLAS-B-RD23-SB20-SNR(L)-AAN

Efficient snack food packaging at dramatically high speeds

Ishida's ATLAS, an ultra high speed and reliable VFFS bagmaker, creates high quality bags for snack foods. This innovative machine reduces product and film waste. The ATLAS also provides smooth integration with weighers and various additional packaging machines.

Dimensions (Unit: mm)

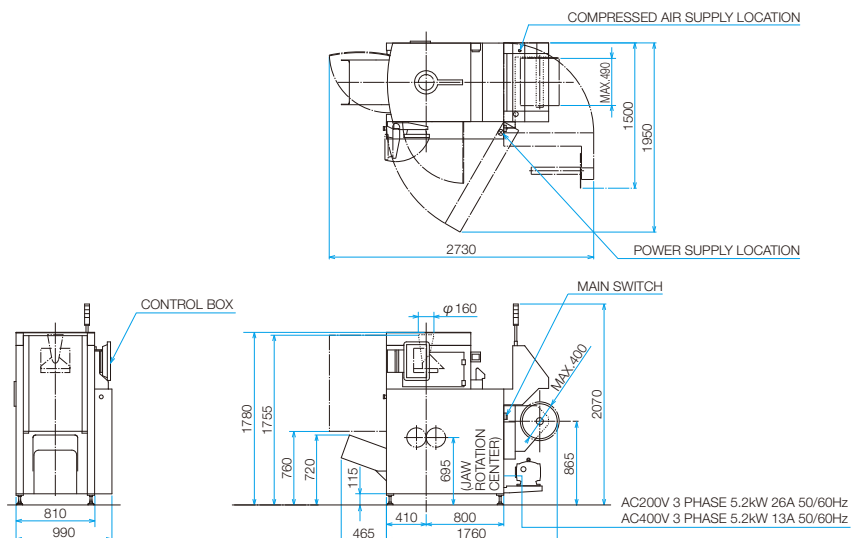

Specification

| Model | | ATLAS-B-RS23-SB20-SNR(L)-AAN | ATLAS-B-RD23-SB20-SNR(L)-AAN |
|-----------------------|-----------------|------------------------------------------------------------------------------------------------------------------------------------------------|-------------------------------------------------------|
| Performance | | | |
| Packaging Speed | | 10-125bpm*1 | 10-250bpm*1 |
| Bag Size | Width | 80 to 230mm (50 to 230mm with small bag option)*2 | |
| | Length | 75-533mm | |
| Film Web Size | | Maximum roll diameter: 400mm Maximum roll width: 490mm | |
| Main Body | Wight | Approximately 1200kg | |
| | Materials | Painted body | |
| HMI | | 15.6" colour CTS (Capacitive Touch Screen) | |
| Number of presets | | 500 | |
| Specification | | | |
| Utilities | Air Consumption | 0.5MPa 60NL/min or less | |
| | Power | 3-phase AC200V 5.2kW 26A 50/60Hz (within $\pm 10\%$ of rated voltage) 3-phase AC400V 5.2kW 13A 50/60Hz (within $\pm 10\%$ of rated voltage) | |
| Operating Environment | | Temperature: 0-40°C Humidity: 30-70%RH (Without dew condensation) | |
| Noise Level | | 85dB or less when running without product (at 125bpm) | 85dB or less when running without product (at 250bpm) |
| IP rating | | IP-30*3 | |

*1) Packaging speed may vary with product shape, packaging material and other conditions.

*2) When bag width is 50-230mm, option compatible with small bag is required.

*3) Based on internal test result.